

# REVOLUTION<sup>®</sup>

Mercedes-Benz Specialists

Mercedes-Benz vehicles are well known for their longevity—but the key factor in achieving this is properly maintaining your vehicle. Much as you rely on your vehicle to get you to where you need to go, your vehicle relies on you to make sure it has everything it needs to stay healthy. This means adopting and adhering to a regular service schedule.

This guide details the recommended services and their intervals.

# RECOMMENDED MAINTENANCE INTERVALS

210 Dekalb Industrial Way  
Decatur, GA 30030

Phone 404 292 2683

[serviceteam@revolutionbenz.com](mailto:serviceteam@revolutionbenz.com)

[www.revolutionbenz.com](http://www.revolutionbenz.com)



REVOLUTION<sup>®</sup>  
Mercedes-Benz Specialists

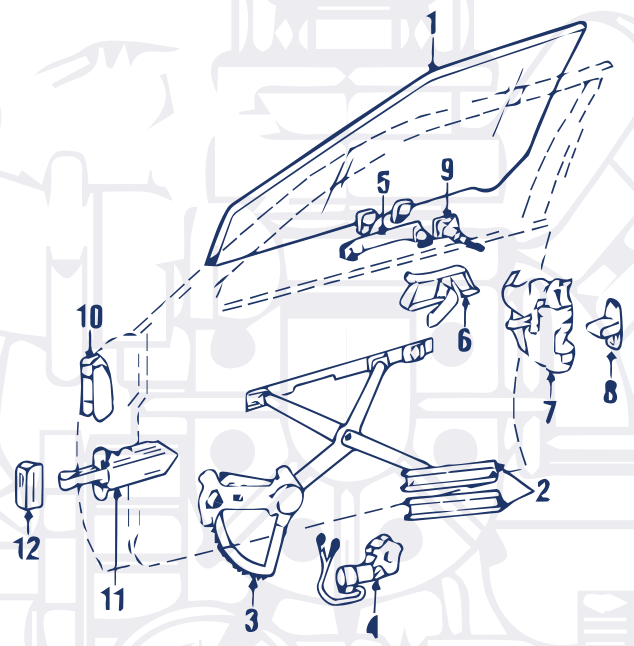

## **Oil Service (1 year or 10,000 miles for the first 100,000 miles; every 5000 miles thereafter)**

- Change oil and filter using Mercedes-Benz approved engine oil and OEM filter
- Check and correct coolant, power steering fluid, and brake fluid levels; if equipped with a dipstick, check and correct transmission fluid level
- Check and correct air pressure in all tires
- Perform basic vehicle inspection
- Clean cowl at base of windshield
- Wash exterior and vacuum interior of vehicle

## **A-Service (1 year or 10,000 miles)**

- Perform Oil Service
- Test drive vehicle checking for driveability issues, handling problems, noises, and other problems
- Test function of windshield cleaning system; clean and aim washer nozzles as necessary
- Check function of all lights and switches
  - Replace exterior bulbs as needed (additional cost will apply)
- Check function of climate control system
- Perform "Quick Test" of vehicle electrical system using the Mercedes-Benz Xentry system ('96 and newer vehicles only)
- Check function of doors, seats, seatbelts, trunk, and tailgate as equipped
- Check condition of spare tire; ensure tools and jack are properly stowed
- Check condition of belt(s) and all belt driven systems; correct tension of belt(s) as necessary
- Inspect engine compartment for issues including but not limited to leaks, noises, and visible damage
- Check fuses in accessible fuse boxes and replace fuses as necessary
- Check condition of all brake components; measure thickness of brake pads and discs
- Rotate tires as necessary
- Lubricate chassis (antique vehicles only)
- Check all steering and suspension components for wear and damage
- Inspect exhaust system for wear, damage, and rust
- Check entire undercarriage for wear, damage, and leaks
- Refill AdBlue tank (Bluetec diesel vehicles only)
- Reset service light, stamp service book and apply next service sticker to windshield

## **B-Service (2 years or 20,000 miles)**

- Perform Oil Service and complete A-Service
- Clean and lubricate door hinges and latches, hood hardware, fuel door hinges, and trunk hinges and latch
- Clean door, trunk, and hood seals and apply Rubber Care protectant
- Clean and lubricate sunroof slides, and antenna mast as equipped
- Clean all body, hvac and sunroof drains
- Adjust parking brake as applicable
- Steam clean engine compartment
- Add injector cleaner to fuel tank

## **A-la-Carte Periodic Maintenance Services**

### **ABC System (60,000 miles)**

- Replace fluid and filter, only for vehicles equipped with active body control

### **Alignment (30,000 miles)**

- Perform 4-wheel vehicle alignment

### **Battery (6 years or 80,000 miles)**

- Replacement recommended

### **Brake Fluid (2 years or 20,000 miles)**

- Clean fluid reservoir and replace fluid

### **Cabin Air Filter (2 years or 20,000 miles)**

- Check filter and replace as needed

- Optional charcoal filter is replaced every 10 years or 100,000 miles if equipped

### **Coolant (10 years or 100,000 miles)**

- Check and flush cooling system as needed

### **Differential Fluid (10 years or 100,000 miles)**

- Replace fluid in differential(s)

### **Drive Belt(s) (8 years or 80,000 miles)**

- Check all drive belts and replace as necessary; replace belt tensioner and idler pulleys as applicable

### **Engine Air Filter(s)**

- Gas vehicles - 4 years or 30,000 miles

- Diesel Vehicles - 2 years or 20,000 miles

- Check air filter(s) and replace as needed

- Clean air filter housing

### **Fuel Filter**

- Gas - 6 years or 60,000 miles

- Diesel - 2 years or 20,000 miles

- Check and replace all fuel filters as necessary

### **Power Steering Fluid (10 years or 100,000 miles)**

- Flush power steering system; replace filter as applicable

### **Spark Plugs (replacement interval varies by engine)**

- Pre-1998 vehicle (3 years or 30,000 miles)

- Most V6 and V8 engines (6 years or 60,000 miles)

- Most 4 Cyl and AMG vehicles (4 years or 40,000 miles)

### **Tire Rotation (2 years or 10,000 miles)**

- Remove all wheels and rotate as needed to extend the life of the tires

### **Transfer Case Fluid (6 years or 60,000 miles)**

- Change fluid in the transfer case; only applicable to 4-matic vehicles without transfer case integrated with transmission

### **Transmission Fluid and Filter (4 years or 40,000 miles)**

- Up to 06/10 - 4 years or 40,000 miles

- As of 06/10 - 6 years or 60,000 miles (722.9 Transmission)

- Replace transmission filter and fluid

*\*Not all services are applicable to all vehicles. Ask your service advisor which services your car wants.*